

REVISIONS				
REV.	DESCRIPTION	ECN	DATE	APPROVED
D	REFER TO ECN	11909	8/12/13	MTH

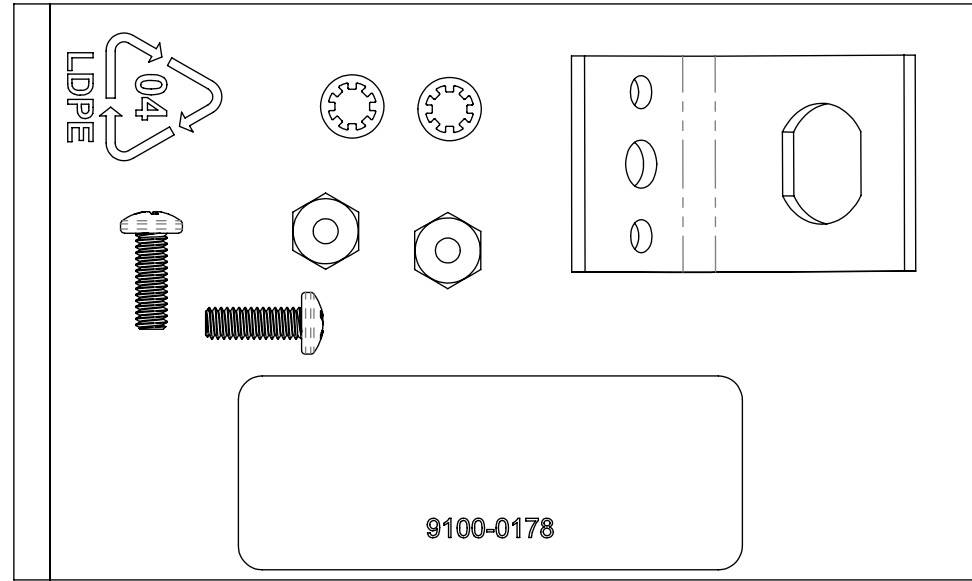
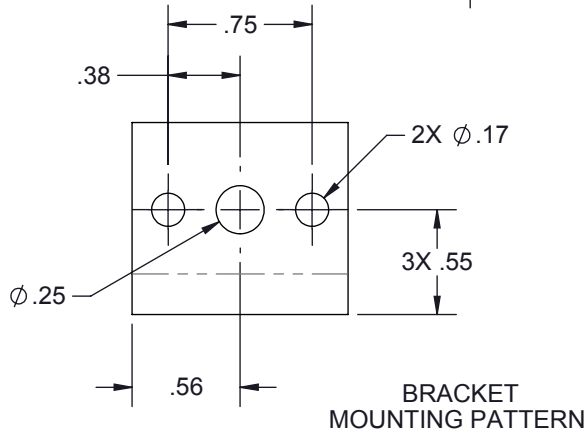
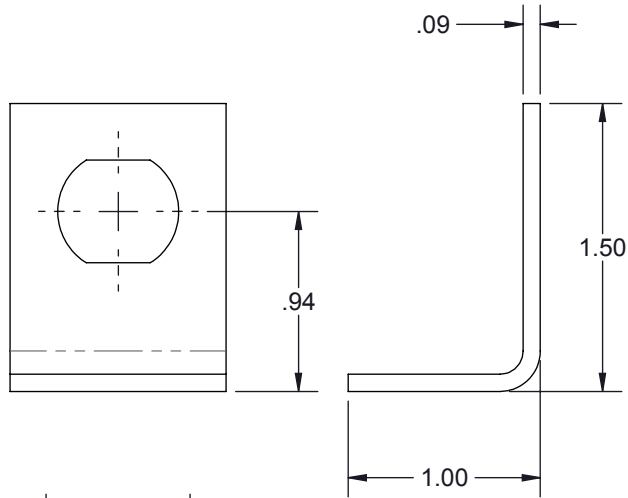

HARDWARE KIT INCLUDES:

QTY	DESCRIPTION
1	BRACKET MOUNT N FLANGE
2	NUT 8-32 HEX 18-8 SS
2	WASHER #8 410 SS INTERNAL
2	SCREW 8-32x.50 PHIL MS PAN 18-8 SS

CUSTOMER APPROVAL: \_\_\_\_\_ DATE: \_\_\_\_\_

ALL DIMENSIONS SHOWN ARE FOR REFERENCE ONLY.

<small>UNLESS OTHERWISE SPECIFIED LEADING DIMENSIONS ARE INCHES DIMENSIONS IN [ ] ARE MILLIMETERS</small> <small>TOLERANCES: FRACTIONS=± 1/32 .XX=± .03 ANGLES=± 1° .XXX=± .010</small> <small>NOTICE: THE INFORMATION AND DESIGN IN THIS DOCUMENT IS THE PROPERTY OF POLYPHASER CORPORATION. ALL RIGHTS RESERVED.</small>	<small>DRAWN</small> SH	<small>DATE</small> 3/26/99			<small>SHEET</small> 1 OF 1		
	<small>ENG APPD</small> RCD	<small>DATE</small> 4/6/99			<small>SCALE</small> 1:1		
	<small>PRODUCT MGR</small> KCB	<small>DATE</small> 4/6/99	<small>TITLE</small> <b>KIT FLANGE/BLKH N ADAPTER</b> <small>CUSTOMER SPECIFICATION</small>				
	<small>MARKETING APPD</small> TF	<small>DATE</small> 4/6/99					
<small>THIRD-ANGLE PROJECTION</small> 	<small>PROJECT NO.</small> 	<small>DOCUMENT NAME</small> BFN-C	<small>SIZE</small> A	<small>CAGE</small> 61114	<small>PROD CAT</small> GRP	<small>PART NUMBER</small> 	<small>REV</small> D

THESE COMMODITIES, TECHNOLOGY OR SOFTWARE WERE EXPORTED FROM THE UNITED STATES IN ACCORDANCE WITH THE EXPORT ADMINISTRATION REGULATIONS. DIVERSION CONTRARY TO U.S. LAW PROHIBITED.